

A-065

Turning AUTO REST®

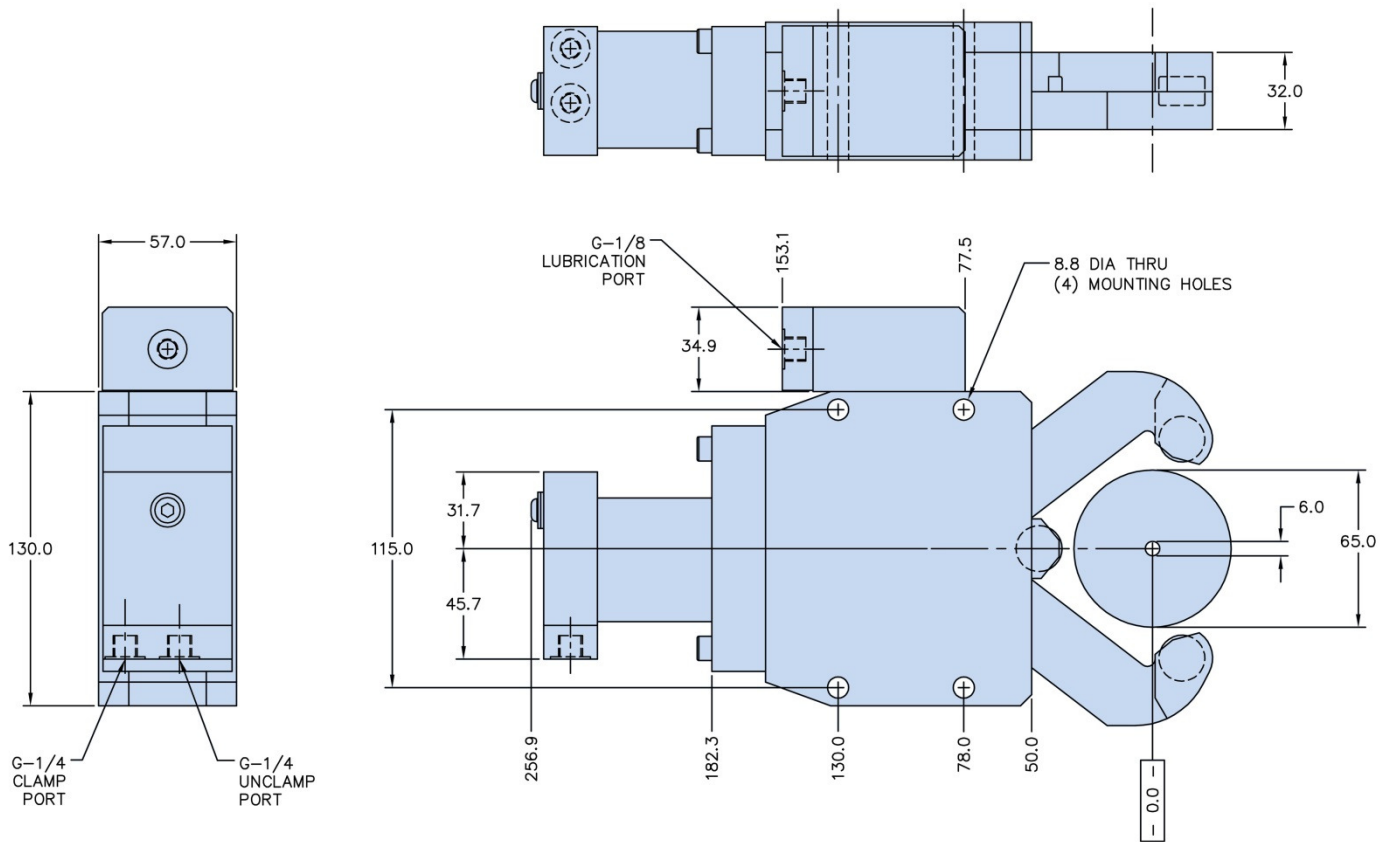

Maximum Clamp Size	mm	65
Minimum Clamp Size	mm	6
Max Workpiece Speed	Meters per Min	535
Max Lifting Capacity	kg	38
Piston Area	cm ²	9.7
Cylinder Stroke	mm	35
Operating Pressure	bar	7 - 28
Maximum Pressure	bar	28
Air Purge Pressure	bar	N/A
Lubrication Frequency		Working Cycle (or every 6 minutes)
Repeatability	mm	±0.005
Centering Accuracy	mm	±0.020
Mass	Kg	8.6

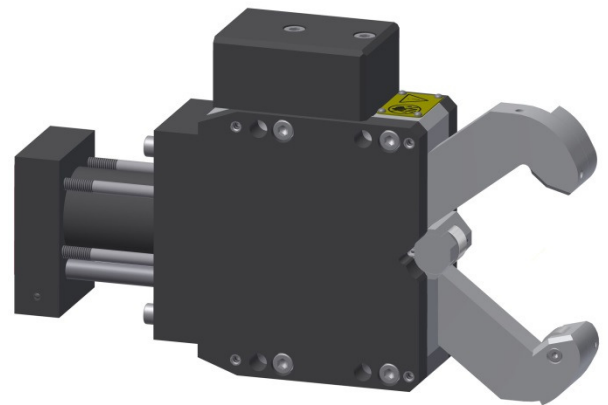

Included Features:
 * Hydraulic Operation
 * Integrated Pilot Operated Safety Check Valve
 * Oil Lubrication

Options:
 * Manual Grease Lubrication