

Turning AUTO REST®

A-250

**** Model A-250 can be ordered with LH or RH Side Mount Cylinder**

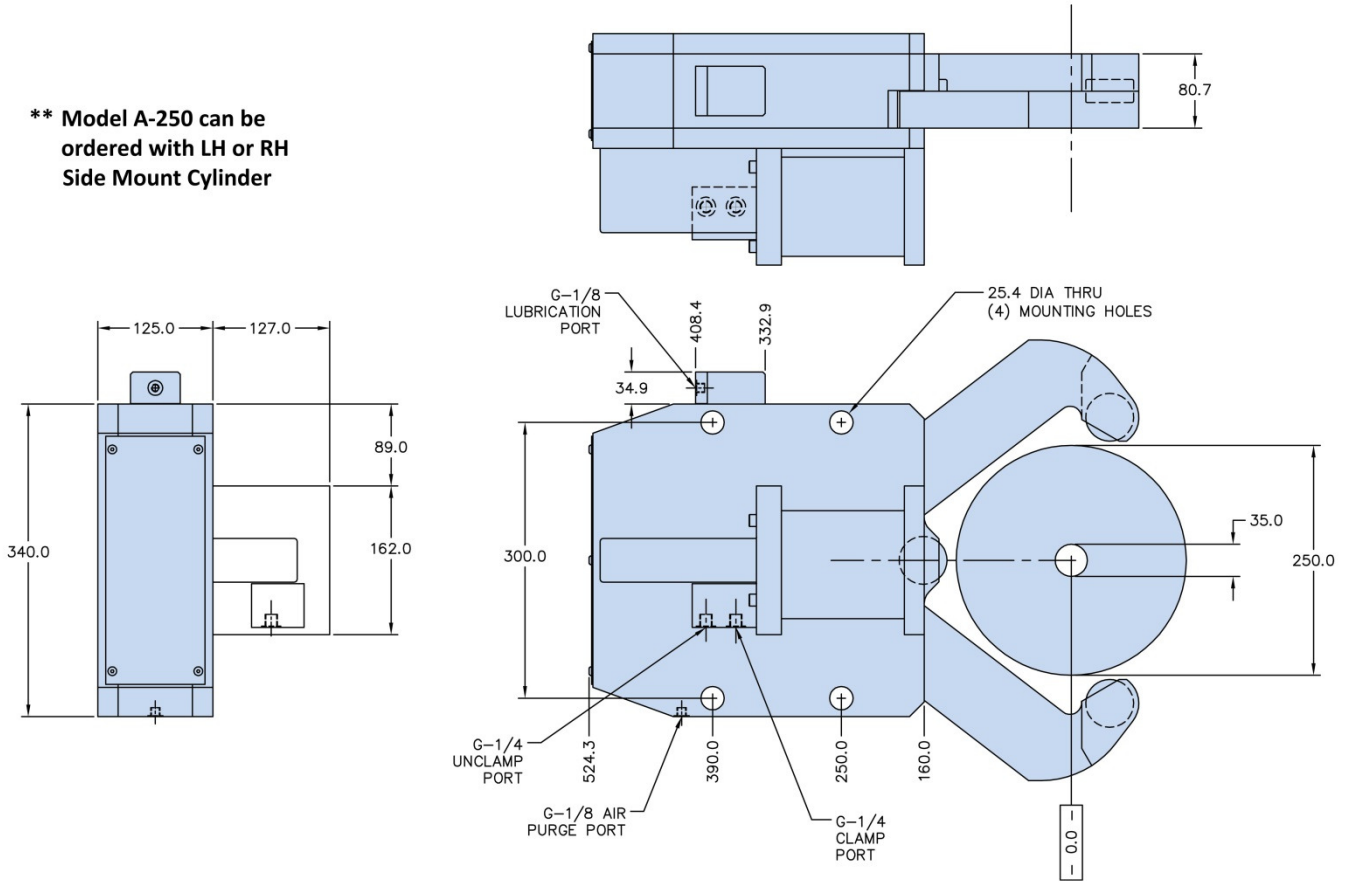

Maximum Clamp Size	mm	250
Minimum Clamp Size	mm	35
Max Workpiece Speed	Meters per Min	615
Max Lifting Capacity	kg	650
Piston Area	cm ²	69.7
Cylinder Stroke	mm	119
Operating Pressure	bar	10 - 40
Maximum Pressure	bar	40
Air Purge Pressure	bar	0.3 – 0.5
Lubrication Frequency		Working Cycle (or every 6 minutes)
Repeatability	mm	±0.007
Centering Accuracy	mm	±0.050
Mass	Kg	132

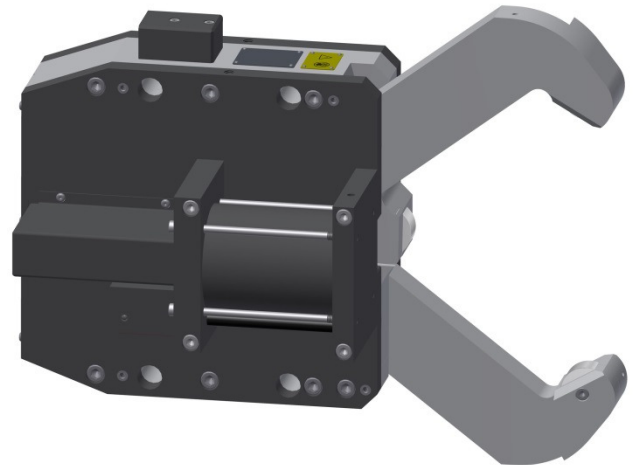

Included Features:

- * Hydraulic Operation
- * Integrated Pilot Operated Safety Check Valve
- * Side Mount Cylinder
- * Oil Lubrication
- * Air Purge

Options:

- * Manual Grease Lubrication
- * Rear Mount Cylinder